

Operating Manual

DOCUMENT CONTROL

Document Name	F783E Ex-ia Intrinsically Safe Operating manual
Document Number	00-ISN-203
Version	B
Date	29/01/2021

CHANGE LOG

Date	Rev.	Change
25/09/2018	A	New release
29/01/2021	B	Added ATEX approvals

We reserve the right to make technical changes without notice.
Technische Änderungen vorbehalten.
Sous réserve de modification techniques.

© Pentair Flow Technologies Pacific Pty. Ltd 2018
Operating Manual

CONTENTS Cont'd

10.	PNEUMATIC INSTALLATION	27
10.1.	Safety instructions	27
10.2.	Pneumatic connections of the control head.....	27
10.3.	Flow restriction function of the solenoid valve	28
11.	ELECTRICAL INSTALLATION	29
11.1.	Electrical connection options	29
11.2.	Electrical data	29
11.3.	Safety instructions	30
11.4.	Electrical installation and start-up.....	31
11.4.1.	Cable gland with spring terminals.....	31
12.	DECOMMISSIONING	23
12.1.	Safety instructions	32
12.2.	Dismantling the F783E control head	32
13.	DISPOSAL	33

1. OPERATING INSTRUCTIONS

The operating instructions describe the entire life cycle of the device. Keep these instructions in a location which is easily accessible to every user, and make these instructions available to every new owner of the device.



WARNING!

The operating instructions contain important safety information!

Failure to observe these instructions may result in hazardous situations.

- The operating instructions must be read and understood.

Symbols:



DANGER!

Warns of an immediate danger!

- Failure to observe the warning will result in a fatal or serious injury.



WARNING!

Warns of a potentially dangerous situation!

- Failure to observe the warning may result in serious injuries or death.



CAUTION!

Warns of a possible danger!

- Failure to observe this warning may result in a moderate or minor injury.

NOTE!

Warns of material damage!

- Failure to observe the warning may result in damage to the device or the equipment.



Indicates important additional information, tips and recommendations.



Refers to information in these operating instructions or in other documentation.

⇒ Designates a procedure which you must carry out.

2. AUTHORISED USE

Incorrect use of the control head F783 EasyMind Ex-ia may be dangerous to people, nearby equipment and the environment.

The control head has been designed for use as actuation of pneumatically operated valves and / or for recording the switching states of these.

The authorised data, the operating conditions and conditions of use specified in the contract documents and operating instructions are to be observed during use. These are described in Chapter "6. Technical Data".

In view of the large number of application options, check and, if required, test prior to installation whether the control head is suitable for the specific application case.

If you are unsure, please contact your Pentair Flow Technologies Pacific Pty. Ltd contact.

The device may be used only in connection with third-party devices and components which have been recommended or approved by Pentair Flow Technologies Pacific Pty. Ltd.

Any unauthorized reconstructions and changes to the control head are prohibited for safety reasons.

Correct transportation, correct storage and installation as well as careful operation and maintenance are essential for reliable and problem-free operation.

For connecting the control head, use line installations that do not cause any mechanical stresses.

Use the device only as intended.

2.1 Export Restrictions

If exporting the system/device, observe any existing restrictions.

3. BASIC SAFETY INSTRUCTIONS

These safety instructions do not make allowance for any:
Contingencies and events which may arise during assembly, operation, and maintenance of the devices.

Local safety regulations - the operator is responsible for observing these regulations, also in relation to the installation personnel.



DANGER!

Danger - high pressure!

Before loosening lines and valves, turn off the pressure and vent the lines.

Danger of explosion when used in explosive atmospheres.

Opening the control top in an explosive atmosphere is only allowed in a non-energised state
Use only cables and cable glands which have been approved for the respective application area and which have been installed according to the respective installation instructions. Do not expose the device to any mechanical or thermal loads exceeding that described in the operating instructions



WARNING!

Warning - Risk of electric shock!

Before reaching into the system switch off the power supply and secure it to prevent restarting!
Observe applicable accident prevention and safety regulations for electrical equipment!

General hazardous situations.

To prevent injuries:

Ensure that the system cannot be activated unintentionally.

Installation and maintenance work, as well as operator control actions may be carried out by authorised and qualified technicians only and with the appropriate tools.

Do not make any unauthorized internal or external changes to the device!

After an interruption in the electrical or pneumatic supply, ensure that the process is restarted in a defined or controlled manner.

The device may be installed and operated only when in perfect condition and in consideration of the operating instructions.
The general rules of technology apply to application planning and operation of the device.

NOTE!**Electrostatic sensitive components**

- The device contains electronic components which react sensitively to electrostatic discharge (ESD). Contact with electrostatically charged persons or objects may be hazardous to these components. In the worst case scenario, they will be destroyed immediately or will fail after start-up.
- Observe the requirements in accordance with EN 61340-5-1 to minimize or avoid the possibility of damage caused by sudden electrostatic discharge!
- Also ensure that you do not touch electronic components when the supply voltage is on!

NOTE!**Risk of damage to property**

- Do not connect any mechanically rigid connection parts, in particular those with long lever arms, as such connections could generate torques that might damage the control head.
- Do not supply the medium connections of the system with liquids or aggressive or flammable media!
- Do not subject the housing to mechanical loads (e.g. by placing objects on it or standing on it).
- Do not make any external changes to the housings of the device. Do not paint housing parts or screws.
- Only use compatible cleaning agents (e.g. isopropanol up to 70%) for cleaning the securely closed control head and always rinse thoroughly with clean water.



Control head F783E Ex-ia was developed with due consideration given to accepted safety rules and is state-of-the-art. Nevertheless, dangerous situations may occur.

4. GENERAL INFORMATION

4.1. Contact address

Check immediately upon receipt of the consignment that the contents are not damaged and that the type and scope agree with the delivery note and packing list.

If there are any discrepancies, please contact us immediately.

Contact address:

Pentair Flow Technologies Pacific Pty. Ltd

12-14 Kaimiro St

Hamilton 3200

T: +64 (0) 7 958 7100

F: +64 (0) 7 958 7101

E: Email: PacificNZHygienicSales@pentair.com

Website: <http://foodandbeverage.pentair.com>

4.2. Warranty

Please refer to our general terms of sales and business.

The warranty is only valid if the control head is used as intended in accordance with the specified application conditions



The warranty extends only to defects in the control head F783E Ex-ia and its components.

We accept no liability for any kind of collateral damage which could occur due to failure or malfunction of the device

4.3. Information on the internet

The operating instructions and data sheets for F783E control top can be found on the Internet at:

<http://foodandbeverage.pentair.com>

START OF CONTROLLED AREA**5. CERTIFICATION DETAILS****5.1. IECEX**

- 1. Manufacturer : Pentair Flow Technologies Pacific Pty. Ltd
- 2. Model : F783E Ex-ia
- 3. Certificate Number : IECEX ITA 11.0016X
- 4. Ex. Marking Code : Ex ia IIB T5 Ga IP65
: Ex ia IIC T5 Gb IP65
: Ex ia IIIC T90°C Da IP65
- 5. Ratings : IP65, 0°C ≤ T_{amb} ≤ 40°C
- 6. Standards : IEC 60079-0:2011 Ed. 6
IEC 60079-11:2011 Ed. 6

5.2. ATEX

- 1. Manufacturer : Pentair Flow Technologies Pacific Pty. Ltd
- 2. Model : F783E Ex-ia
- 3. Certificate Number : TÜV 16 ATEX 7985X
- 4. Ex. Marking Code : II 1G Ex ia IIB T5 Ga
: II 2G Ex ia IIC T5 Gb
: II 1D Ex ia IIIC T90°C IP65 Da
- 5. Ratings : IP65, 0°C ≤ T_{amb} ≤ 40°C
- 6. Standards : EN 60079-0:2012/A11:2013
: IEC 60079-11:2012

5. CERTIFICATION DETAILS (Cont'd)

5.3. Conditions of Certificate

- ◆ It is a condition of safe use that the apparatus must be mounted so that there is a low risk of mechanical damage.
- ◆ The Valve Control Top F783E Ex-ia version may only be used as explosion safe after proper installation to the process equipment (e.g. actuator) either directly or via a suitable mounting adaptor so that an ingress protection degree to a minimum of IP65 has been achieved.
- ◆ The equipment is to be cleaned with a damp cloth to ensure the minimization of electrostatic charge build up.
- ◆ The equipment is not to be mounted in direct sunlight
- ◆ It is up to the user to provide correct barrier components in accordance with the guidelines in this manual
- ◆ The maximum ambient temperature the intrinsically safe version of the equipment used in Group IIC applications may be increased to 50°C, in which case the temperature classification of T100°C applies

END OF CONTROLLED AREA

6. SYSTEM DESCRIPTION

6.1. Intended application area

The control head F783E Ex-ia has been designed for use as actuation of pneumatically operated process valves and / or for recording the switching states of these.

6.2. General description

The control head F783E Ex-ia is used for actuating pneumatically operated hygienic process valves.

For process valve actuation, the control head can be equipped with a single 2/5 solenoid valve.

For the recording and feedback of the process valve switching positions to a higher-level control, the control head has been equipped with two position feedback switches. These are NAMUR style 2-wire inductive proximity switches.

The F783E Ex-ia control head mounts directly on standard Pentair actuators of figure number F257 and F272S. This produces an integrated, compact and decentralized system of actuation, valve function and feedback. The following advantages over centralised solutions working with valve clusters are achieved:

- low installation expenditure
- easy start-up
- shorter switching times and less air consumption due to shorter distances between the pilot valve and the process valve.

There is a wide range of mounting options available for many other brand actuators in the hygienic food and beverage industry, as well as common industrial actuators. Please consult a customer services representative for more details on mounting options available.

6.3. Functions/options/designs

6.3.1. Structure of the control top

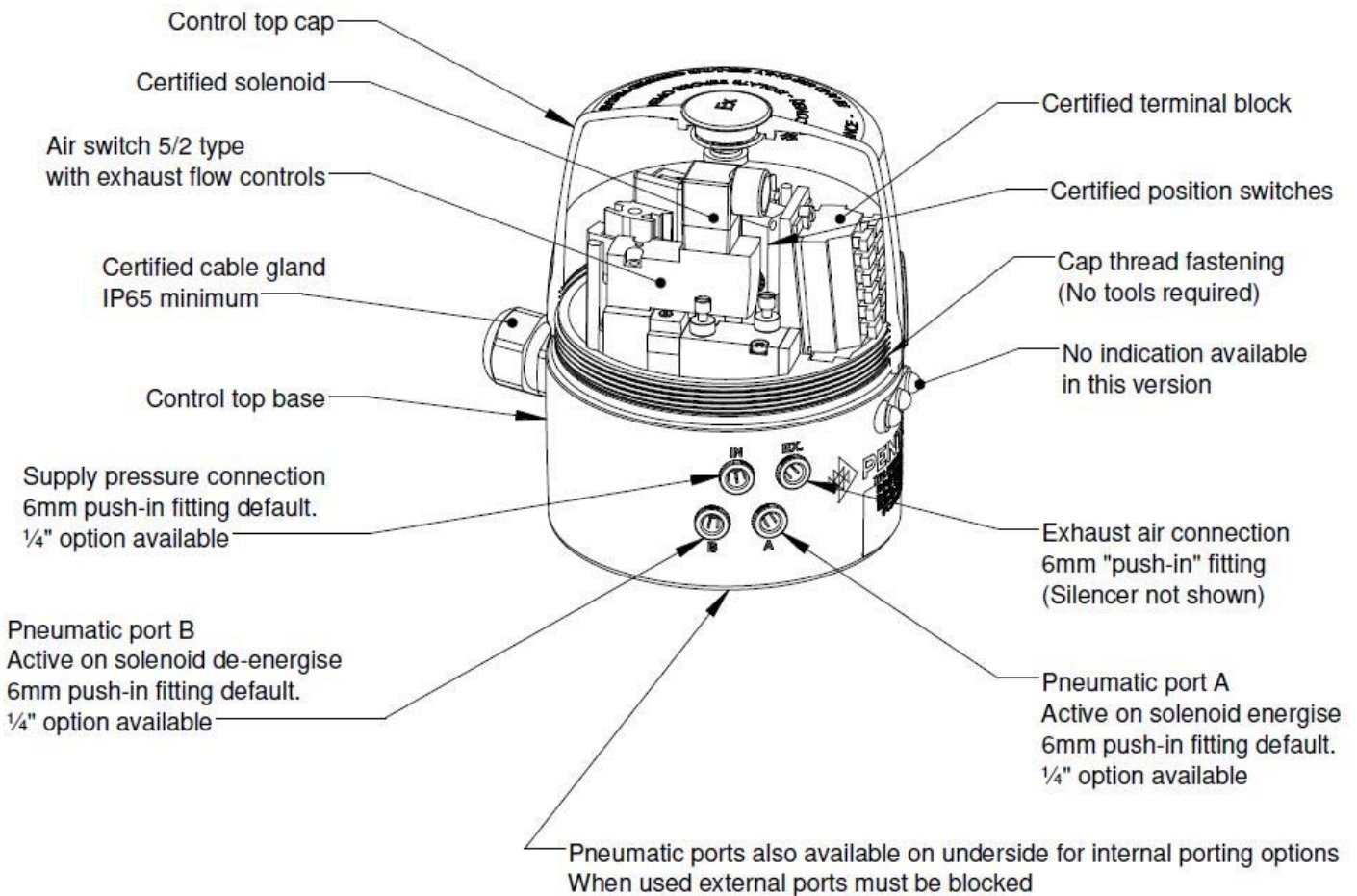

Fig 1: Structure of the control top

6.3.2. Fluid diagram

Control head F783E Ex-ia—fluid diagram (with restriction capability for solenoid valve)

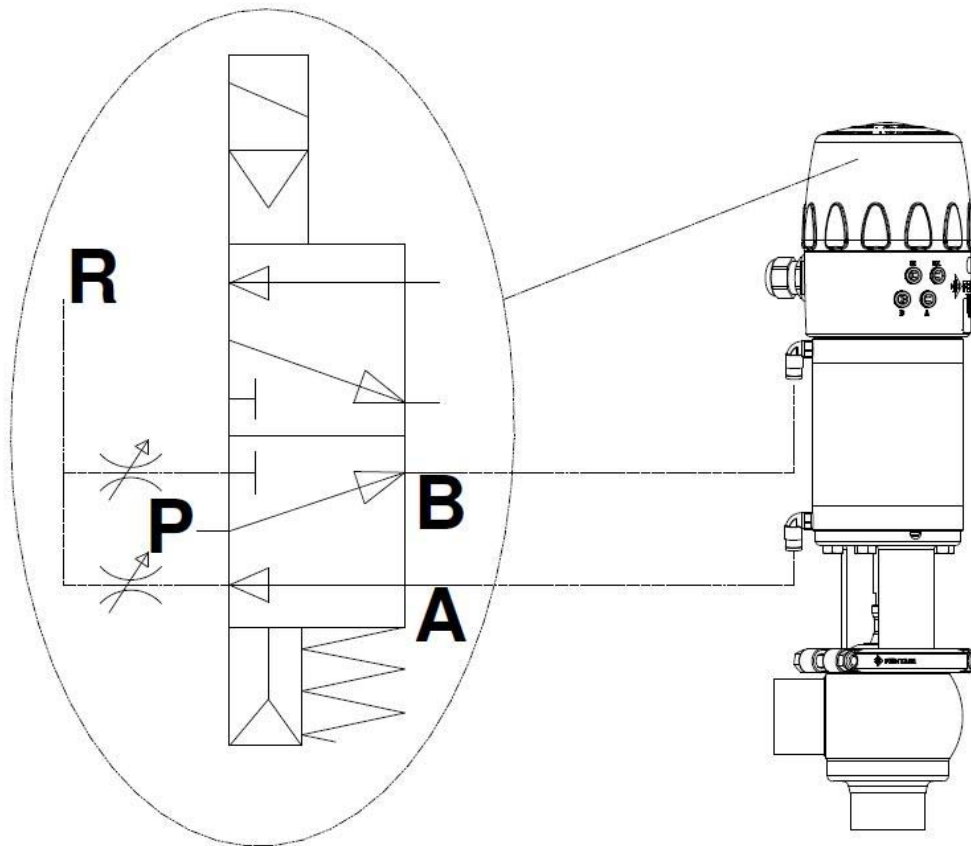

Fig 2: Pneumatic circuit for SMC SYJ5315 air switch as installed in the F783E Ex-ia control head

6.3.3. Number of solenoid valves

The F783E Ex-ia control head for process and butterfly valves has been designed for single-acting and double-acting valve actuators as well as for double seat and multi-position valves using a single solenoid valve.

The air switch is a 5/2 type, with common exhaust. Flow restrictors are installed in the exhaust line of both ports, meaning the operating speed of the actuator can be controlled in both directions

6.3.4. Pneumatic interfaces

Intake & exhaust air connections: 6.0mm “One Touch” push in air fittings

Working connections: 6.0mm “One Touch” push in air fittings or internal porting option when fitted to the F257 type actuator (for ¼ turn operation) Integrated flow regulator in the air switch exhaust air ports

6.3.5. Manual control

The pilot solenoid valve is provided with a push button to operate the pilot valve manually.

The SMC SYJ5153 air switching valve has also a manual operator, which is partially obscured by the pilot valve, so should not be used.

6.3.6 Position monitoring system

The switching positions of the actuator are reported to the control system by feedback signals from two switches mounted on switch pillars within the housing.

The height and orientation of these switches can be adjusted to accommodate the stroke length of all F257 and F272S type actuators. This is achieved by adjusting the screw on the switch pillar to raise or lower the switch and turning the switch around in the retaining clip.

The ¼ turn actuators use a special adjustable target set to accommodate target rotation between 0 and 180°.

7. TECHNICAL DATA

7.1. Operating conditions



DANGER!

Danger of explosion when used in explosive atmospheres.

Opening the control top in an explosive atmosphere is only allowed in a non-energised state
Use only cables and cable glands which have been approved for the respective application area and which have been installed according to the respective installation instructions. Do not expose the device to any mechanical or thermal loads exceeding that described in the operating instructions



WARNING!

Risk of injury from overheating of the control head.

Ambient temperature:

Ex-ia version: 0° ... +40 °C (Max. 95% humidity; non-condensing)

General hazardous situations.

To prevent injuries:

- Ensure that the system cannot be activated unintentionally.
- Installation and maintenance work, as well as operator control actions may be carried out by authorised and qualified technicians only and with the appropriate tools.
- Do not make any unauthorized internal or external changes to the device!
- After an interruption in the electrical or pneumatic supply, ensure that the process is restarted in a defined or controlled manner.
- The device may be installed and operated only when in perfect condition and in consideration of the operating instructions.
- The general rules of technology apply to application planning and operation of the device.

Degree of protection:

Ex-ia version:

IP65 according to EN 60529

(only if cables, plugs and sockets have been connected correctly, the cap has been sealed correctly and the adaptation to the process valve was done correctly)

7.2. Conformity to the following standards

- Certain variants only of the control head F783 EASYMIND Ex-ia comply with the EC directives according to the EC Declaration of Conformity. The applied standards which are used to demonstrate compliance with the Directives are listed in the EC Declaration of Conformity. This may be requested from Pentair Flow Technologies Pacific Pty. Ltd.
The specifications on the respective rating plate apply to the respective control head. The symbols on the rating plate indicate the applicable directives or approvals:

7.3. Mechanical data

Fig. 3: Dimensional drawing – Ex-ia version

Weight:	approx. 0.7 kg
Housing material:	exterior: PA66 + PA6, TSC10/4, EC inside: ABS
Sealing material:	exterior: EPDM (O-rings) Santoprene (gasket) inside: NBR

7.4. Pneumatic data

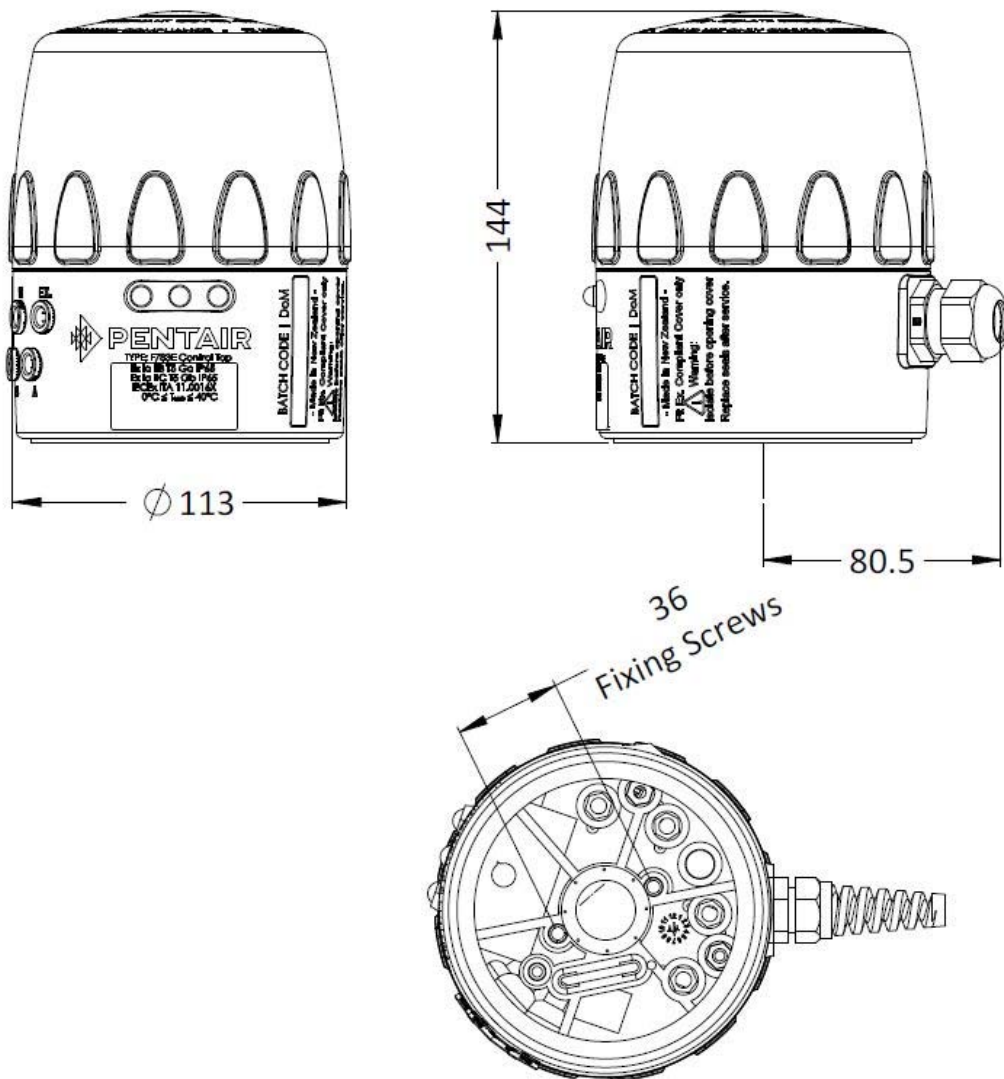

WARNING!

Use clean dry air

Do not use compressed air which contains chemicals, synthetic oils containing organic solvents, salts or corrosive gases, etc., as this can cause damage or malfunction.



CAUTION!

Install air filter

Install air filters close to valves at their upstream side. A filtration degree of 5 µm or less should be selected.

Install an air dryer, after cooler or Drain Catch (water separator) etc.

Air that includes excessive moisture may cause malfunction of valves and other pneumatic equipment. To prevent this, install an air dryer, after-cooler, or water separator, etc.

If excessive carbon dust is generated

Eliminate it by installing mist separators at the upstream side of valves. If excessive carbon dust is generated by the compressor, it may adhere to the inside of valves and cause malfunction.

Control medium:	Air, neutral gases Quality classes in accordance with DIN ISO 8573-1 (5µm filter recommended)
Dust content Quality class 7:	max. particle size 40µm max. particle density 10mg/m ³
Water content Quality class 3:	max. pressure dew point -20°C or min. 10°C below the lowest operating temperature
Oil content Quality class X:	max. 25mg/m ³
Temperature range of compressed air:	-10 ... +50° (non-condensing)
Pressure range:	3.0 ... 7 bar (minimum air pressure of system may be higher than minimum pressure to operate solenoid, as required by product conditions, valve or actuator)
Connections:	6mm "One touch" push-in fittings, collets and O-rings are replaceable

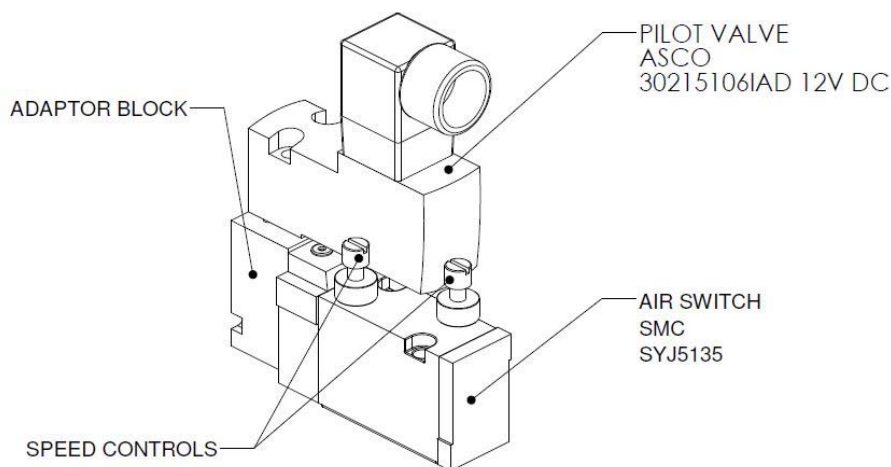

Fig. 5: Solenoid operated air switch

The exhaust flow rates for both ports can be controlled separately to control the actuator speed in both energising and de-energising directions

7.5. Position system data

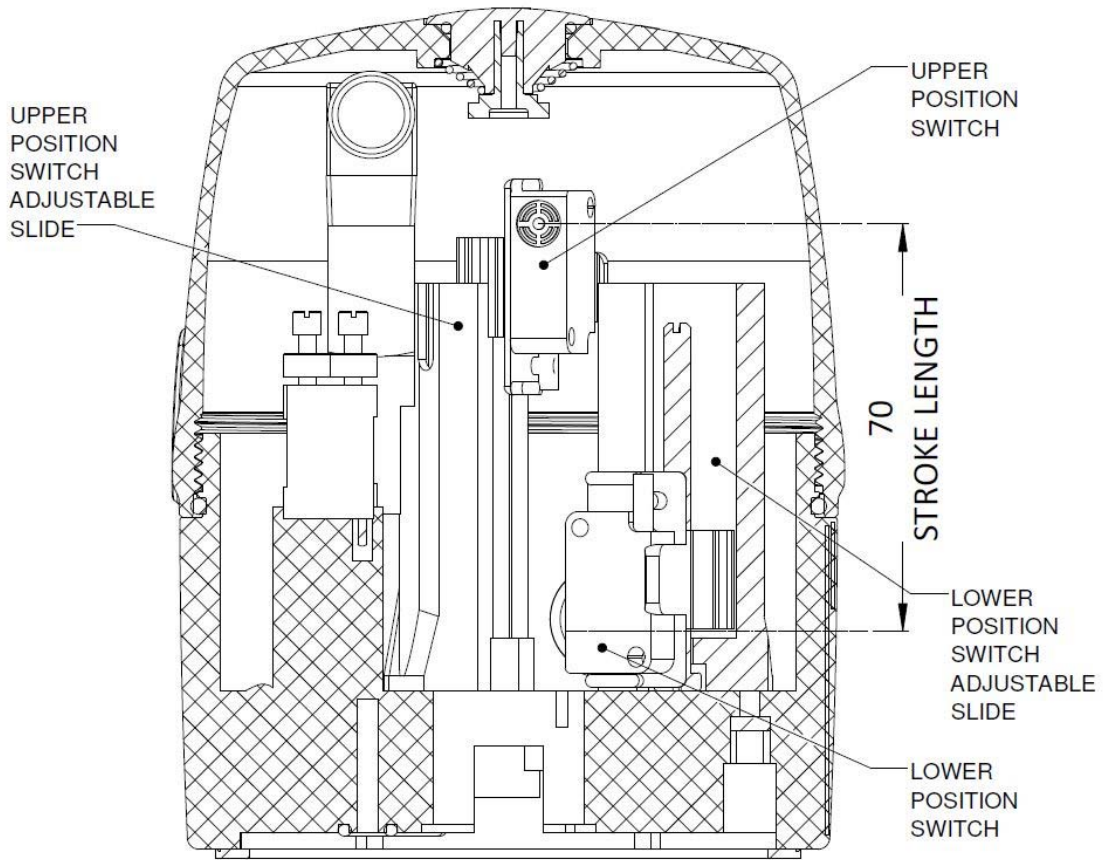

Fig. 6: Section view of control head on linear actuator

8. INSTALLATION

8.1. Safety instructions

Always wear the appropriate PPE for the situation. Use correctly sized tools for operations that require tools



DANGER!

Risk of injury from high pressure in the system

- Before loosening any lines and valves turn off the pressure and vent the valves



WARNING!

Risk of injury from overheating of the control head.

- ⇒ Before accessing the inside of the F783E Ex-ia control head, isolate any control power which may be hazardous to the health of the operator.
- ⇒ Ensure the control head is safe to work on – secure the system against unintentional activation
- ⇒ Avoid leaving live loose wires which can contact ground or each other and initiate protective devices.
- ⇒ When commissioning and testing the control head, before manually operating the actuator ensure it is safe to do so. Ensure operating the valve won't compromise personal or product safety. Keep hands clear of moving parts at all times.

8.2. Assembly of the control head

The control head can be installed in any installation position. Ensure there is sufficient height above the control head to remove the cap and adjust the switches.

The device should be installed such that layers of dust thicker than 5 mm cannot form; meaning that such should be ensured through correspondingly regular cleaning.

Risk of injury from improper assembly!

Do not improperly stress the control head.

Do not apply any leverage effect on the head and do not climb on it.

For the installation of the F783E Ex-ia control head to a linear-type actuator, you will require an actuator-specific target. Be sure to order the correct target for that actuator.

For installation of the F783E Ex-ia control head on a rotary-type actuator, the target will always be the same. Depending on the type and brand of actuator an adaptor kit may be required.

When mounting the F783E Ex-ia control head on a **PENTAIR** brand F257 or F272S actuator no special mounting adaptor is required.

8.2.1. Mounting the base

NOTE!

- **Maximum supply cable length is to be 30m. Control top must be installed in the same building as the control cabinet.**
- **Installation environment and wiring are influential on the module's EMC: Thus the installer must secure EMC of the whole device.**
- **According to Norm EN 61326-1: 2006 (chart 2) DC supply connections to the module are treated as input/output signal lines. For cable lengths greater than 30 m and outdoor applications additional measures must be implemented in order to comply with CE**

8.2.1.1. Fitting the control head—Linear actuator

If installing on the F272S actuator, remove and discard the metal O-Ring retaining plate/cover. Fit the O-Ring retaining bush (supplied with the actuator) over the actuator shaft, small diameter uppermost, to secure the actuator shaft O-Ring.

1. Fit the linear target assembly to the shaft of the piston valve actuator. Tighten using a Hex key.
2. The height of the switches have been factory set to operate when used on a F257 1/4 turn actuator, so the Open switch, which is opposite the **solenoid**, must be inverted in order to achieve sufficient height adjustment. To do this turn the switch tower adjusting screw clockwise until the switch carrier is flush with the top of the screw. Prise the holding clip outwards gently until the switch comes free with a gentle tug. Rotate the switch so the target area is uppermost and set back into the switch holder, make sure the retaining clip snaps over the switch (see Limit Switch Setting below for adjustment procedure).
3. Locate the Base Gasket on to the step on the top of the actuator or mounting kit adaptor.
4. Fit the two Base O-Rings into the round & oval recesses in the base of the control head, the larger O-Ring is supplied round and will need to be worked into its oval recess. DO NOT apply grease, the O-Rings will be easier to fit and keep in place if kept dry and not lubricated.
5. Fit the control head over the target assembly onto the actuator or adaptor plate. Check any mounting holes do not foul the Base O-Rings while orienting the air ports towards the actuator air ports.
6. Fasten the Control Head down by means of the two M6 socket head cap screws. Torque down to 3.5 NM.
7. Connect the air lines from the actuator to the control head to suit the actuator and valve combination. Port “B” is live when the solenoid is de-energised, the “A” port is live when the solenoid is energised.
8. Connect the air supply to the Control Head port labelled “IN”. If it is safe to do so the actuator can be operated using the manual override on the solenoid. Check for leaks.
9. Tighten the cable gland firmly using an appropriate spanner.

8.2.1.2. Limit Switch Setting

This procedure is simplified if the control head is connected to a power source, as the LED’s on the switches (if present) will indicate. It is best to adjust the switches such that the target is just coming into the switch detection zone.

1. Operate the valve to the fully OPEN (up) position by operating the manual override switch on the pilot valve.
2. Using a small flat blade screwdriver adjust the switch opposite the **solenoid** by turning the height adjustment screw, clockwise raises the switch, anticlockwise lowers the switch. If power is not available align the centre of the target symbol on the switch with the middle of the metal target.
3. Operate the valve to fully closed (down) position. Adjust the switch opposite the **terminal block** by turning the height adjustment screw.
4. Release the manual override if used, before fitting the cap O-Ring and screwing the cap firmly down.

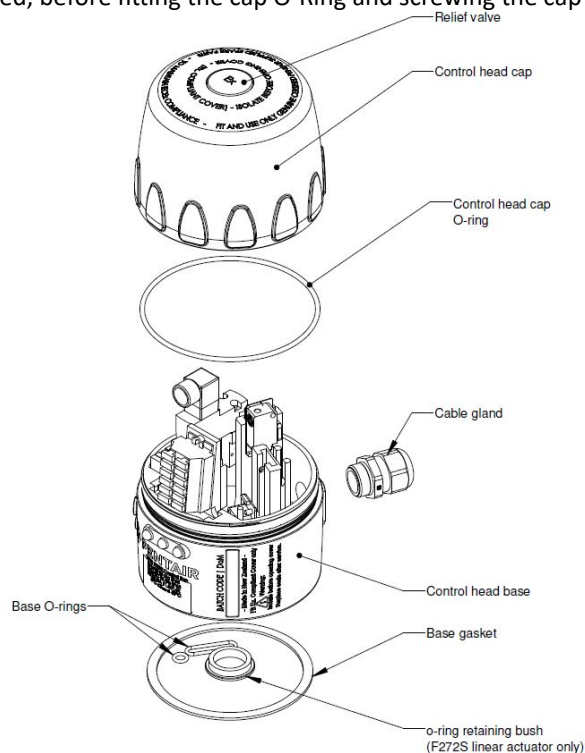

Fig 7. Mounting - Linear Components

8.2.1.3. Fitting the control head—Rotary actuator

1. Secure the rotary target assembly to the indicator shaft of the F257 ¼ turn actuator or actuator mounting kit. Ensure the grub screw (set screw) locates into the dimple provided on the drive flat.
2. Locate the rubber base gasket on to the step on the top of the actuator or mounting kit adaptor.
3. Fit the two O-rings into the round & oval recesses in the underside of the base of the control head, the larger O-ring will need to be worked into its recess. It is better NOT to apply grease, the O-ring will be easier to fit and keep in place if not lubricated.
4. Fit the control head over the target assembly onto the actuator, ensuring the O-rings in the base of the head line up with the internal air porting in the top of the actuator. When the control head is being fitted to any actuator other than the F257 ¼-turn, the external air porting is used and the adaptor will blank off these ports. Check any mounting holes do not foul the O-rings.
5. Fasten the head down by means of the two M6 socket head cap screws. Torque down to 3.5 NM. Do not over tighten.
6. Fit the two plugs supplied with the rotary target assembly into ports 'A' & 'B' in the control head.

Note: When the control head is used in an application other than the internally ported F257 actuator, Port B is "live" when the solenoid is De-energised, and Port A is "live" when the solenoid is Energised.

8.2.1.4. Limit Switch and Rotary Target Setting**Setting the switch height:**

The height of the switches have been factory set for use on the F257 ¼-turn actuator. If the control head is fitted to another actuator the switch heights may need to be adjusted to suit the target height. The switch to indicate the open position is opposite the terminal block, the switch to indicate closed is opposite the solenoid. The target area of the switches (the crosshairs) should line up with the metal target cams.

To adjust the switch height, turn the adjusting screw (through the switch holder) to raise or lower the switch.

Setting the target cams:

1. Operate the actuator to the fully open position, using the manual solenoid control button.
2. Slacken the central screw (slotted head screw) on the rotary target assembly one full turn.
3. Adjust the top cam by turning the adjusting screw marked 'OPEN' with a small flat blade screwdriver so the target is lined up with the centre of the switch.
4. Operate the actuator to the fully closed position
5. Adjust the bottom cam by turning the adjusting screw marked 'CLOSED' using the screwdriver so the target is lined up with centre of the switch.
6. After setting the cams, re-tighten the central clamping screw firmly and check that the switch setting is as required.
7. The above procedure is made simpler if the control head module is connected to the power source as you will see the position LED's working.
8. If necessary adjust the solenoid valve speed controls to control the opening and closing speed of the actuator. Make sure they are locked off properly before closing up.

8.2.2. Pneumatic and electrical connections**Pneumatic installation**

See Chapter "10. Pneumatic Installation"

Electrical installation

see Chapter "11. Electrical Installation"

Recommended auxiliary materials

ROCOL Sapphire Silicone grease for lubrication of the control head cap thread and O-ring seal. Alternatively use Klüber Paraliq GTE 703.

9. OPENING AND CLOSING THE HOUSING

9.1. Safety instructions

**DANGER!****Danger of explosion when used in explosive atmospheres.**

Opening the control top in an explosive atmosphere is only allowed in a non-energised state

Use only cables and cable glands which have been approved for the respective application area and which have been installed according to the respective installation instructions. Do not expose the device to any mechanical or thermal loads exceeding that described in the operating instructions

**DANGER!****Risk of injury from high pressure in the system**

- Before loosening any lines and valves turn off the pressure and vent the valves

**WARNING!****Risk of injury due to electric shock!**

Before opening the control head and prior to reaching into the system assess the risk from accidental contact with live conductors.

Observe applicable accident prevention and safety regulations for electrical equipment!

Risk of injury from improper installation!

Installation may be carried out by authorized technicians only and with the appropriate tools!

Risk of injury from unintentional activation of the system and uncontrolled restart!

Secure system against unintentional activation.

Following installation, ensure a controlled restart.

9.2. Opening and closing the housing

NOTE!**Improper handling will damage the plastic cap or sealing o-ring!**

Do not use excessive force (e.g. by knocks) for opening. Hand grips are provided to assist removing and replacing the cap. In severe cases a strap wrench may be used.

9.2.1. Opening the housing

Procedure:

- Unscrew the cap by rotating in an anti-clockwise direction.

9.2.2. Closing the housing

If required clean all sealing faces and check for damage to threads and sealing surfaces.

- Make sure that the seal face is clean and not damaged when the cap is fitted as this might reduce the IP protection!
- Ensure all wires are in the appropriate wire restraints so none can be caught in the threads and potentially damaged.
- Ensure no cables are interfering with the relief valve mechanism in such a manner as to allow the ingress of water or jamming the relief valve which could result in a build-up of pressure in the enclosure.

Procedure:

- Lightly lubricate the O-ring sealing face on the cap and the cap thread with a silicone-based lube such as ROCOL Sapphire Silicone or Klüber Paraliq GTE 703
- Place the cap over the interior components, ensuring no wires are caught in the thread.
- Twist the cap in an anti-clockwise direction until hearing a click, this will indicate the thread start, now rotate in a clockwise direction until the cap is securely tightened. There should be minimal O-ring showing at the cap/base interface, and the relief valve should be seated properly on the top of the cap. If the relief valve is raised, remove the cap and check the relief valve is operating properly and no internal components are interfering with the operation of the relief valve mechanism. Refit the cap.

10. PNEUMATIC INSTALLATION

10.1. Safety instructions

DANGER!

Risk of injury from high pressure in the system

- Before loosening any lines and valves turn off the pressure and vent the valves

WARNING!

Risk of injury from improper installation!

- Installation may be carried out by authorized technicians only and with the appropriate tools!

Risk of injury from unintentional activation of the system and uncontrolled restart!

- Secure system against unintentional activation.
- Following installation, ensure a controlled restart.

10.2. Pneumatic connections of the control head

DANGER!

Risk of injury from high pressure in the system

- Before loosening any lines and valves turn off the pressure and vent the valves

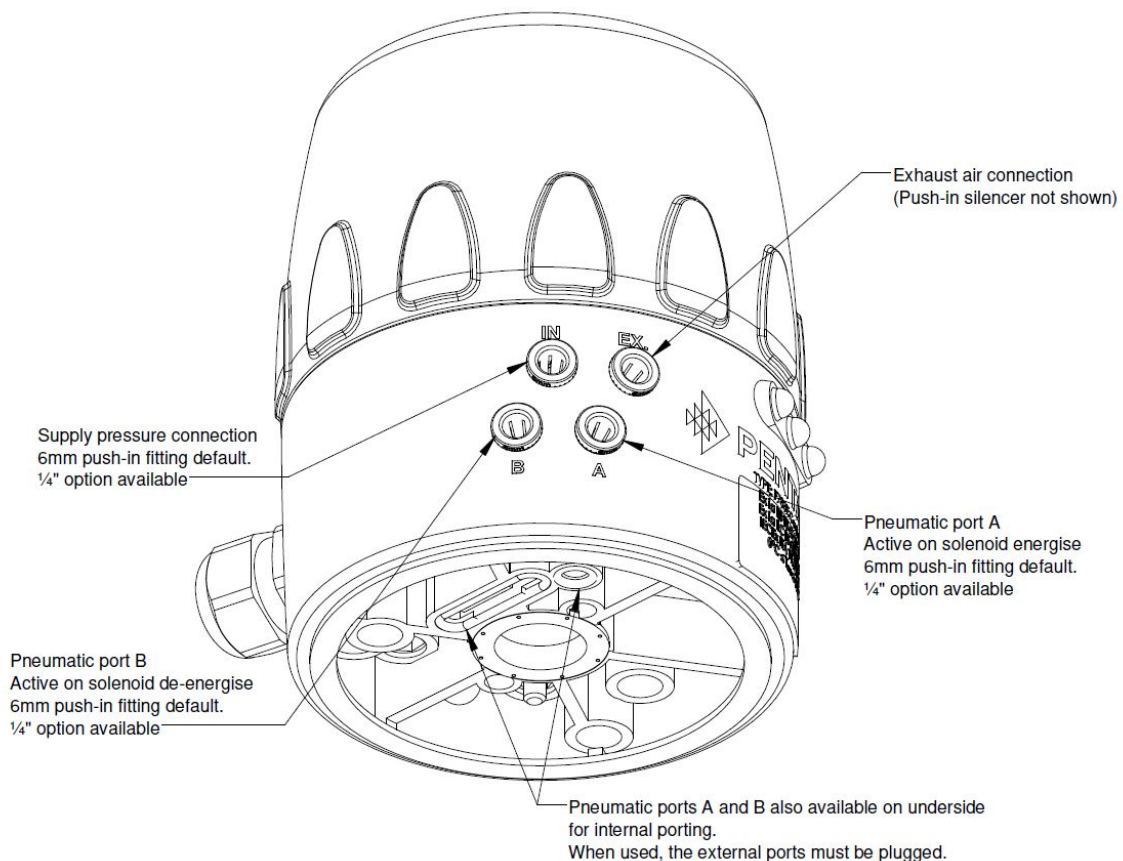

Fig 8. Pneumatic connections

Procedure

The control head can be positioned in two orientations with respect to the actuator, as set by the two mounting bolts that retain the control head onto the actuator or adaptor.

- ⇒ In the case of the F257 rotary actuator, only one position will allow the use of the internal porting facility. The other position will blank the internal ports.
- ⇒ In the case of a linear actuator choose the orientation that is most convenient for the routing of the airlines from the control head to the actuator control ports.

The exhaust is fitted with a silencer on leaving the factory. If required this can be replaced with an exhaust airline by removing the exhaust silencer from the one-touch fitting and installing an airline of the correct size. The default size for the F783E Ex-ia is 6mm air tube.

NOTE!

- ⇒ Use only airlines of the correct size for the fittings installed. If in doubt, the size of the airline is imprinted on the air fitting collet.
- ⇒ Always use a hose cutter designed for the air tube. Scissors, saws and knives are not suitable hose cutters.
- ⇒ Allow sufficient length on airlines to avoid kinking of the tube, or tension on the fitting. Either will lead to premature failure of the airline, and possible injury or product loss.
- ⇒ Always use an airline of the required quality to suit the environment.
- ⇒ If using an exhaust airline, ensure the length and bore of the airline do not restrict the flow from the actuator to exhaust.

10.3. Flow restriction function of the air switch

⇒ Set the flow restriction function of the air switch only when required and after completion of all necessary installation. The flow restriction screws on the solenoid valve are used to control the rate of flow from the exhaust of the two sides of the cylinder.

Once the desired flow rate has been set tighten the locking nuts to prevent the screws moving during operation

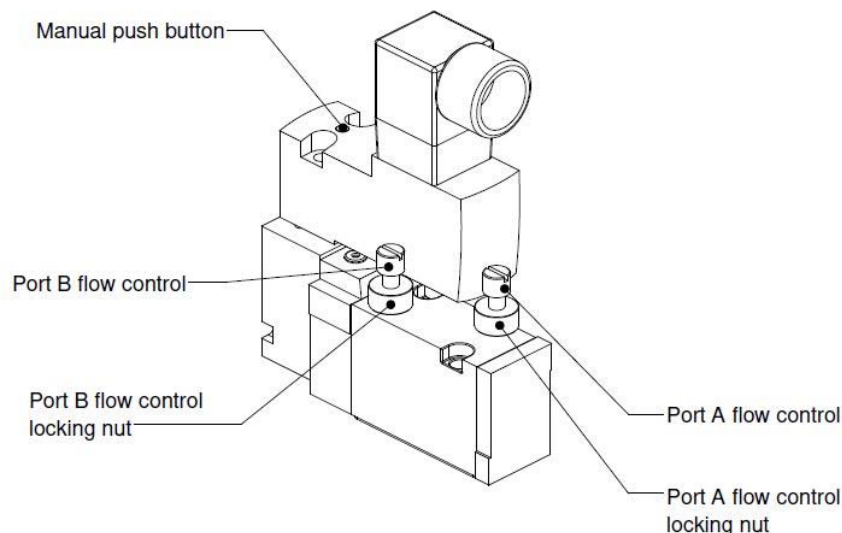

Fig 9: Setting the exhaust flow restrictors

Once the flow screws are set, close the housing in accordance with the instructions in Chapter 8 “Opening and closing the control head”

11. ELECTRICAL INSTALLATION

11.1. Electrical connection options

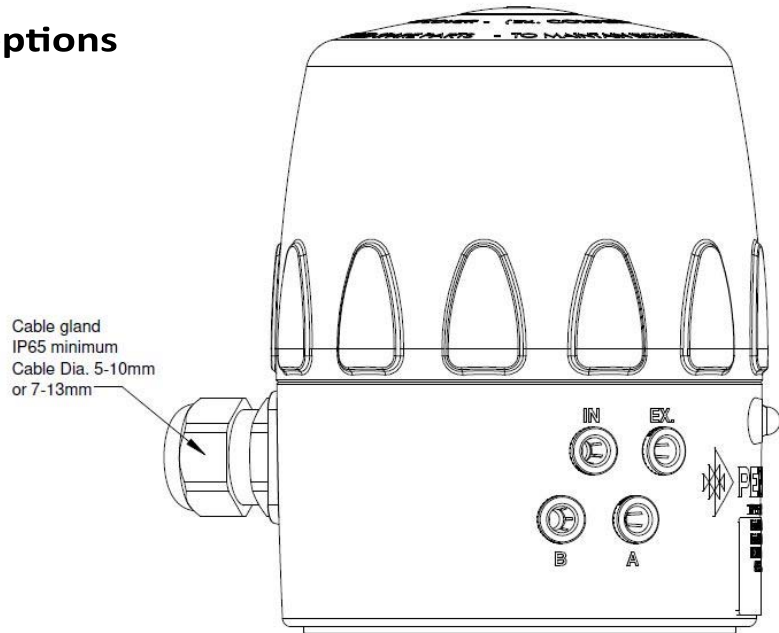

Fig 11: Electrical connection options

11.2. Electrical data

Connections:

Cable gland version: 1 x M20 cable gland c/w strain relief for power supply and signals, for cable diameter 5–13 mm,

Terminals	Parameters	
1, 2 (ifm NS5002 Proximity Switch or ifm NS5003 Proximity Switch)	Ui	15 V
	Ii	50 mA
	Pi	120 mW
	Ci	80 nF
	Li	110 µH
3, 4 (ifm NS5002 Proximity Switch or ifm NS5003 Proximity Switch)	Ui	15 V
	Ii	50 mA
	Pi	120 mW
	Ci	80 nF
	Li	110 µH
5, 6 (ASCO pilot valve 30215106IAD 12VDC)	Ui	28 V
	Ii	300 mA
	Pi	1.6 W
	Ci	0 µF
	Li	0 µH

11.3. Safety instructions

**DANGER!****Danger of explosion when used in explosive atmospheres**

Opening the control top in an explosive atmosphere is only allowed in a non-energised state

Use only cables and cable glands which have been approved for the respective application area and which have been installed according to the respective installation instructions. Do not expose the device to any mechanical or thermal loads exceeding that described in the operating instructions

**WARNING!****Risk of injury due to electric shock!**

- Before reaching into the system isolate the power supply when it is deemed the power supply could be capable of causing injury from electric shock!
- Observe applicable accident prevention and safety regulations for electrical equipment!

Risk of injury from improper installation!

- Installation should only be carried out by qualified personnel and only with the appropriate tools

Risk of injury, product loss or damage from unintentional activation of the system and uncontrolled operation of the output!

- Secure the system against unintentional activation
- Following installation ensure a controlled restart

11.4. Electrical installation and startup

11.4.1. Cable gland with spring terminals

Procedure:

- ⇒ Open the control head (follow the instructions in chapter 8 “Opening and closing the housing” if in doubt)
- ⇒ Prepare the cable by stripping back the outer sheath to expose approximately 120mm of the cores. Strip each core to expose 6 to 8mm of bare copper.
- ⇒ Insert the cable through the cable gland until the outer sheath is able to be secured by tightening the gland
- ⇒ Twist each core firmly before fitting to the terminals of the 6-way terminal block as in Fig 12.
- ⇒ Use a screwdriver or similar tool to depress the spring terminal latches, insert the wire and release the latch.
- ⇒ Close the housing (follow the instructions in chapter 8 “Opening and closing the housing” if in doubt)

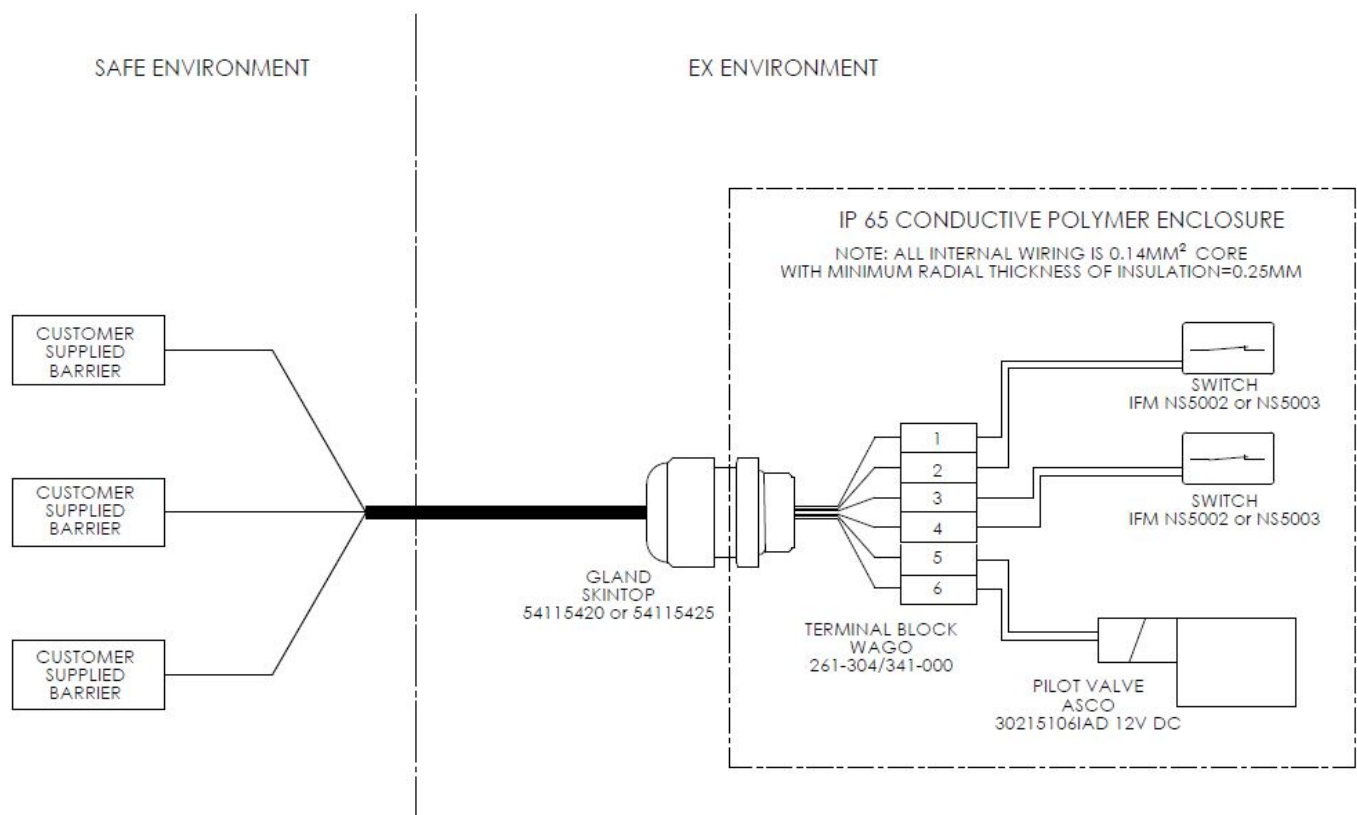

Fig 12: Electrical connection

NOTE!

Ensure IP protection is maintained!

- To ensure the control head IP rating is maintained the cable gland nut must be tightened securely, the cap O-ring must be in good condition and in place and the relief valve must be fitted correctly and it's O-ring in place.
- All unused air connections should be fitted with a sealing plug

12. DECOMMISSIONING

12.1. Safety instructions

**DANGER!****Danger - high pressure!**

Before loosening lines and valves, turn off the pressure and vent the lines.

Danger of explosion when used in explosive atmospheres (only in the event of a fault in zone 2)

Opening the control top in an explosive atmosphere is only allowed in a non-energised state

**WARNING!****Risk of injury due to electric shock!**

- Before reaching into the system isolate the power supply when it is deemed the power supply could be capable of causing injury from electric shock!
- Observe applicable accident prevention and safety regulations for electrical equipment!

Risk of injury from improper disassembly!

- Disassembly work should only be carried out by qualified personnel and only with the appropriate tools

15.2. Dismantling the F783E Ex-ia control head

! Prior to starting work, check the system status. Confirm all system power is isolated and it is safe to disconnect cables

Procedure:

Cable gland version

- ⇒ Open the control head (follow the instructions in chapter 8 “Opening and closing the housing” if in doubt).
- ⇒ Disconnect the cable terminations from the terminal block. Slacken the gland nut and pull the cable through the gland.
- ⇒ Loosen the pneumatic connections (for detailed instructions see chapter 9 “Pneumatic installation”).
- ⇒ Remove the two M6 caphead screws that retain the control head to the actuator.
- ⇒ Lift the control head clear of the actuator and any target.
- ⇒ If necessary, remove the target and any adaptor plates (if fitted).
- ⇒ Refit the cap to maintain the internal components in good condition.
- ⇒ Store or dispose of the control head in accordance with the guidelines in chapter 13

13. DISPOSAL

⇒ Dispose of the device or components in an environmentally responsible manner

NOTE!

Damage to the environment caused by device components contaminated with media

- Observe the relevant disposal and environmental protection regulations
- Observe national waste disposal regulations