

250
PSI

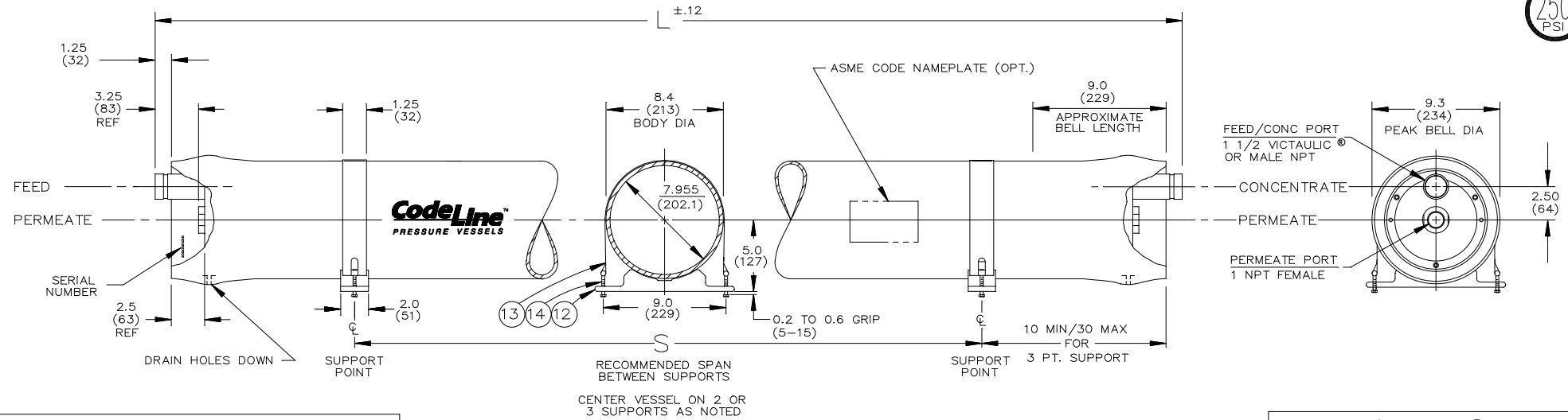

Dwg. Ref.	Qty. Per	Part Number	Part Name	Materials/Remarks
SHELL				
①	1	107031- -1,-2,-3,-4,-5 -6,-7,-7.5,-8	Shell Length	Filament wound epoxy/glass composite- Head locking grooves integrally wound in-place
HEAD				
②	2	407082-1	Bearing Plate	6061-T6 aluminum alloy-hard anodized
③	2	407002-1	Sealing Plate	PVC Thermoplastic
④	2	407083-1	Feed/Conc Port	Type 316 Stainless Steel
⑤	4	6CR003-187	Port Retainer	Type 304 Stainless Steel
⑥	2	407084-1	Permeate Port	PVC Thermoplastic
⑦	2	6ER002-442	Head Seal	Ethylene propylene, Quad Ring
⑧	4	6ER001-225	Port Seal	Ethylene Propylene, O-Ring
HEAD INTERLOCK				
⑨	6	407288-1	Locking Ring	Cast Aluminum-hard anodized
⑩	2	407007-1	Securing Ring	Reinforced Plastic - Yellow Color
⑪	6	6CF016-1	Securing Screws	316 Stainless Steel
VESSEL SUPPORT				
⑫	*2	407333-1	Saddle	Engineering Thermoplastic
⑬	*2	207078-2	Strap Assy	304 Stainless Steel - PVC cushion
⑭	4	6CF007-14	Strap Screw	5/16-18 UNC, 18-8 Stainless Steel
ELEMENT INTERFACE				
⑮	2	As Required	Adapter	Engineering Thermoplastic
⑯	1	407052-2	Thrust Ring	Thermoplastic, White
⑰	2	6ER001-221	Adapter Seal	Ethylene Propylene - O-Ring
⑱	4	As Required	PWT Seal	Ethylene Propylene - O-Ring
*3 each furnished with length code 6, 7, 7.5 & 8.				

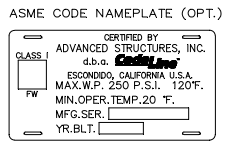
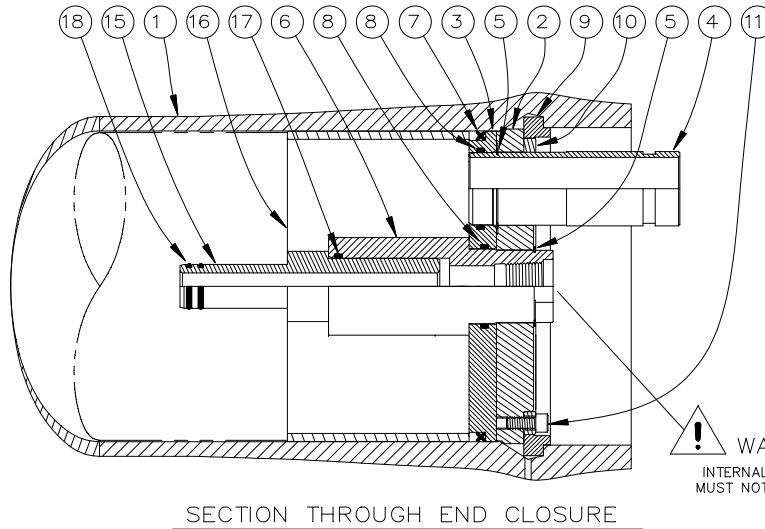

NOTES:
• DIMENSIONS IN INCHES (MM APPROX)
• NOT TO BE USED FOR CONSTRUCTION UNLESS CERTIFIED

Shell Length Code	L L.O.A. IN (MM)	S Span IN (MM)	Empty Weight LB (KG)
1	61.0 (1550)	34 (864)	55 (25)
2	101.0 (2565)	56 (1422)	70 (32)
3	141.0 (3581)	80 (2032)	90 (41)
4	181.0 (4597)	104 (2642)	110 (50)
5	221.0 (5613)	128 (3251)	125 (57)
6	261.0 (6630)	* 3 PTS.	145 (66)
7	301.0 (7645)	* 3 PTS.	165 (75)
7.5	321.0 (8153)	* 3 PTS.	175 (80)
8	341.0 (8661)	* 3 PTS.	185 (84)

CodeLine™
PRESSURE VESSELS
by
CodeLine DIVISION
STRUCTURAL NORTH AMERICA
Escondido, California U.S.A.

ENGR AP 20NOV97	MODEL E8U MEMBRANE HOUSING				
QLTY RAP 21NOV97					
MRKT DWE 20NOV97	SCALE NONE	SHEET 1 OF 1	SIZE B	NUMBER 507007	REV K

RATING:

DESIGN PRESSURE..... 250 PSI at 120°F
(1.7 MPa at 49°C)
 MIN. OPERATING TEMP..... 20°F
(-7°C)
 FACTORY TEST PRESSURE..... 375 PSI
(2.6 MPa)
 BURST PRESSURE..... 1500 PSI
(10.2 MPa)

INTENDED USE

The Model E8UFiberglass RO Pressure Vessel is designed for continuous, long-term use as a housing for reverse osmosis membrane elements to desalt typical brackish waters at pressures up to 250 psi. Any make of eight-inch nominal diameter spiral-wound element is easily accommodated; the appropriate interfacing hardware for the element specified is furnished with the vessel.

The model E8U is designed in accordance with the engineering standards of the Boiler and Pressure Vessel Code of the American Society of Mechanical Engineers (ASME Code). At small additional cost, vessels can be inspected during construction by an ASME Authorized Inspector and ASME Code stamped.

The Model E8U must be installed, operated and maintained in accordance with the precautions listed and good industrial practice to assure safe operation over a long service life.

The high performance reinforced plastic shell must be allowed to expand under pressure; undue restraint at support points or piping connections can cause leaks to develop in the shell. The end closure, incorporating close-fitting, interlocking metal components, must be kept dry and free of corrosion; deterioration can lead to catastrophic mechanical failure of the head.

CodeLine Division, Structural North America will assist the purchaser in determining the suitability of this standard vessel for their specific operating conditions. The final determination however, including evaluation of the standard materials of construction for compatibility with the specific corrosive environment, shall be the responsibility of the purchaser. Alternate materials with enhanced corrosion resistance are available on special order.

Specifications subject to change without notice.

PRECAUTIONS

- DO... read, understand and follow all instructions; failure to take every precaution will void warranty and may result in vessel failure
- DO... mount shell with drain holes down on horizontal members at central span "S" using compliant vessel supports furnished; tighten hold down straps just snug
- DO... provide overpressure protection for vessel set at not more than 105% of design pressure
- DO... inspect end closures regularly; replace components that have deteriorated and correct causes of corrosion
- DO NOT...make rigid piping connections to ports or clamp vessel in any way that restricts growth of fiberglass shell under pressure; ▲DIA = 0.02 in. (0.5mm) and ▲L = 0.3 in. (8mm) for a length code -6 vessel
- DO NOT...hang piping manifolds from ports or use vessel in any way to support other components; branch connection piping may be simply supported between the header and port; maximum weight of branch piping; feed/concentrate - 16 lbs (7 kg); permeate - 8 lbs (4 kg)
- DO NOT...operate vessel at pressures and temperatures in excess of its rating
- DO NOT... operate vessel without permeate ports internally connected with a complete set of elements and interconnecting hardware
- DO NOT...operate vessel with permeate pressure in excess of 125 psi at 120°F (0.9 MPa at 49°C)
- DO NOT... overtighten the connection to the permeate port (hand-tighten plus one-quarter turn, check for leaks.)
- DO NOT...tolerate leaks or allow end closures to be routinely wetted in any way
- DO NOT... pressurize vessel until double checking to verify that all three segments of Locking Ring Set are in place, and that the Securing Ring is fully seated and secured by all three Securing Screws
- DO NOT...work on any component until first verifying that pressure is relieved from vessel

For complete information on proper use of this vessel please refer to the E8 Series USER'S GUIDE, Bulletin 507011B

ORDERING

Please specify the following:

- VESSEL MODEL NUMBER built from table of options below
- MEMBRANE ELEMENT MODEL NUMBER
- SPECIFIC CONCERNS regarding INTENDED USE and requests for SPECIAL MATERIALS of CONSTRUCTION

A vessel model number specifies a complete assembly less element interface components. The required interface components are furnished with the vessel but are specified separately.

Membrane elements and between-element connectors (interconnectors) are furnished by membrane element manufacturer.

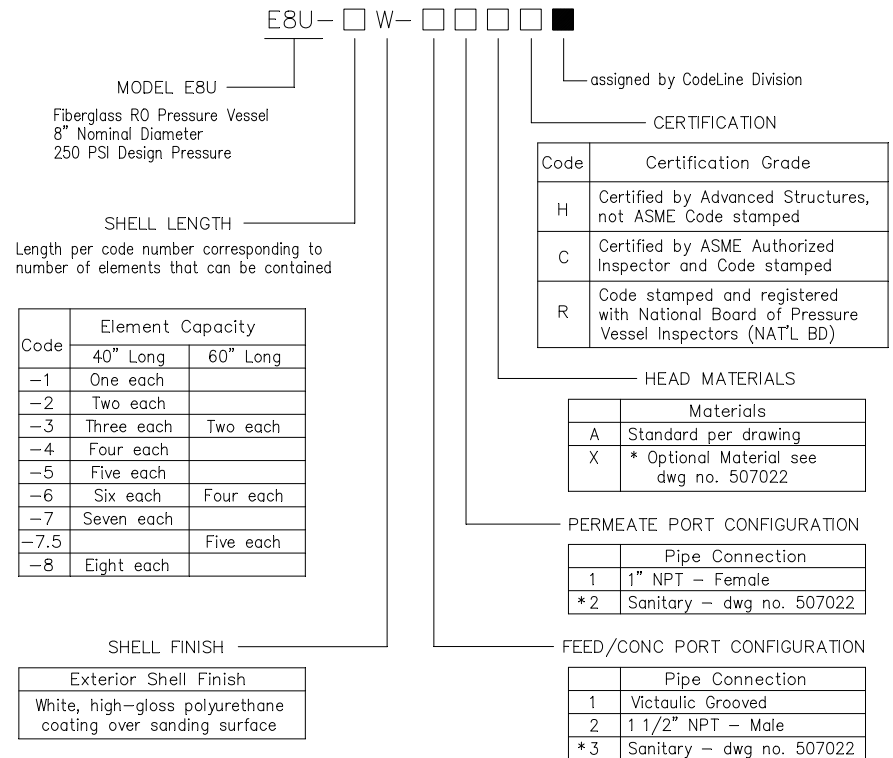

* OPTIONAL - Consult factory for specifications and pricing

